

Anybus® Communicator™ CAN - PROFIBUS INSTALLATION SHEET



HMS Industrial Networks AB
Box 4126
300 04 Halmstad, Sweden
info@hms.se



SP1307, Rev 2.10, AB7312

www.anybus.com

Module Front

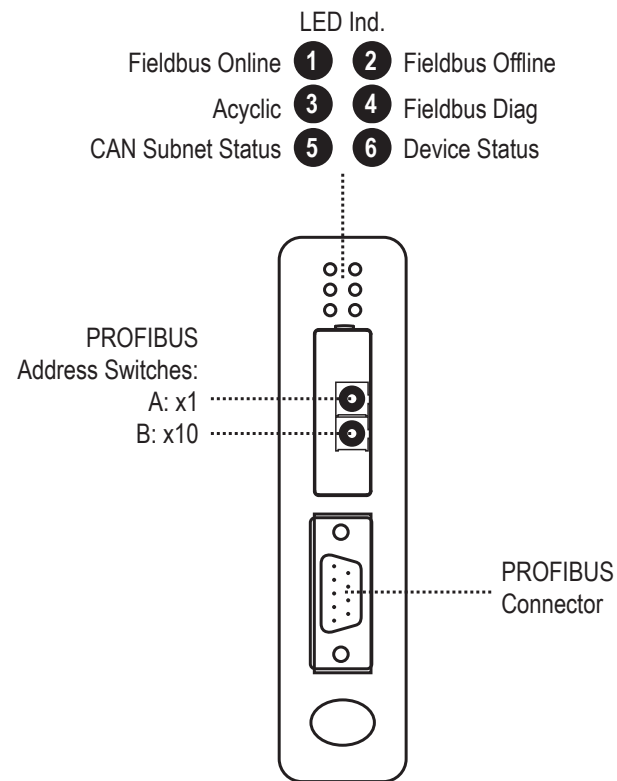

LED Indicators

LED no	Indication	Meaning
1 (Fieldbus Online)	Off Green Flashing green Red	No power/fieldbus not online Fieldbus online, data exchange possible Clear mode Application stopped
2 (Fieldbus Offline)	Off Red	No power/fieldbus not offline Fieldbus offline
3 (Acyclic)	Off Green	No power/no DP-V1 request is currently being executed DP-V1 request is currently being executed
4 (Fieldbus Diag)	Off Flashing red, 1 Hz Flashing red, 2 Hz Flashing red, 4 Hz	No power or no diagnostics present Configuration error Parameter Data error Error in initialization of the PROFIBUS communication ASIC
5 (CAN Subnet Status)	Off Green Flashing red Red	Power off/no CAN communication Running with no transaction errors/timeout Transaction error/timeout or subnetwork stopped Fatal error
6 (Device Status)	Off Alternating red/green Green Flashing green Red	Power off/initializing Invalid or missing configuration Run Idle Fatal error

Accessories Checklist

The following items are required for installation:

- Anybus Configuration Manager - Communicator CAN (available at www.anybus.com)
- CAN cable (included D-sub can be used)
- USB cable (type B) for configuration download
- PROFIBUS cable (not included)

PROFIBUS Note:

- A GSD file for the PROFIBUS interface of the Communicator is available for download from the support pages at www.anybus.com.

Installation and Startup Summary

- Build the configuration in the Anybus Configuration Manager.
- Set the PROFIBUS address switches to the desired values.
- Mount the Communicator at its proper position.
- Connect the USB, PROFIBUS and CAN cables (if needed, use cables with terminations or add terminations).
- Power up the module and download the configuration.
- Remove the USB cable.

PROFIBUS Connector

Pin no	Description
1	Shield
3	B Line
4	RTS
5	GND Bus*
6	+5 V OUT*
8	A Line
Casing	PE
2, 7, 9	(not connected)

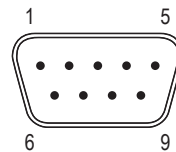

* Pins 5 and 6 are used for bus termination. Some devices, like optical transceivers (RS485 to fibre optics) may require external power supply from these pins. Such devices are not allowed to draw more than 80 mA from these power pins.

PROFIBUS Address Switches

Rotary switch	Meaning
A	Address x1
B	Address x10

Bottom View

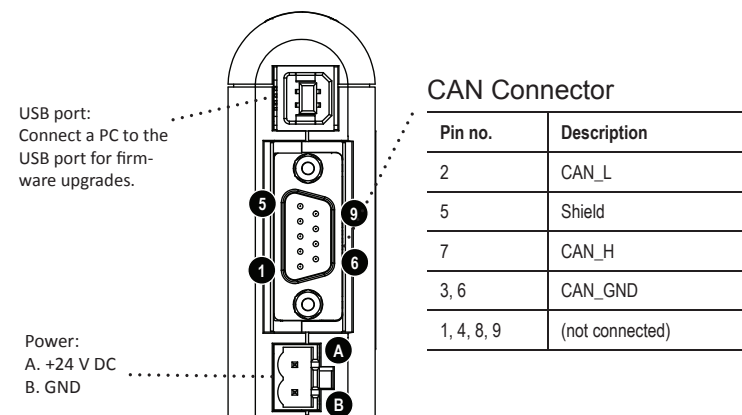

CAN Connector

Pin no.	Description
2	CAN_L
5	Shield
7	CAN_H
3, 6	CAN_GND
1, 4, 8, 9	(not connected)

Technical Details

- Power supply:
24 V DC (-10% to +10%).
- Power consumption:
Maximum power consumption is 250 mA @ 24 V DC.
Typical power consumption: 100 mA @ 24 V DC.
- Protective Earth (PE):
Internal connection to PE via DIN-rail.
Note: Make sure the DIN-rail is properly connected to PE.

PROFIBUS Support

Technical questions regarding the PROFIBUS fieldbus system should be addressed to your local PROFIBUS user group.

Online: www.profibus.org

For maintenance and support, contact the HMS support department. Contact information is available at the support pages at www.anybus.com.

Further information and documents about this product can be found at the product pages on www.anybus.com.

Anybus® Communicator™ CAN INSTALLATION SHEET

DIN Rail Mounting

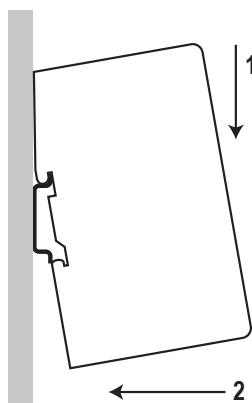

To mount the gateway on a DIN rail, first press it downwards (1) to compress the spring in the rail mechanism, then push it against the rail as to make it snap on (2).

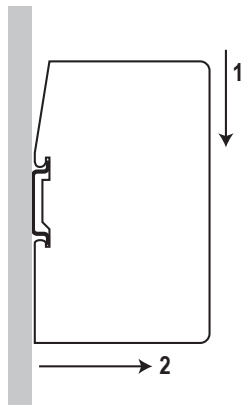

To dismount the gateway, push it downwards (1) and pull it out from the rail (2).

Additional Installation and Operating Instructions

This equipment requires a regulated 24 V (21.6 V to 26.4 V) DC power source

Field wiring terminal markings (wire type (Cu only, 14-30 AWG))
Use 60/75 or 75 °C copper (Cu) wire only.
Terminal tightening torque: 5–7 lb-in (0.5–0.8 Nm)

Use in Overvoltage Category I Pollution Degree 2 Environment conforming to EN 60664-1.

Operating temperature/Surrounding temperature:
-25 to +55 °C @ 250 mA @ 24 V DC

Maximum surface temperature: 135 °C

Pressure: 850–1050 millibar (85–105 kPa)

This product is designed to safely operate in class I, division 2 Hazardous location according to ANSI/ISA 12.12.01-2013 and category 3, zone 2 according to EN 60079-0:2012 and EN 60079-15:2010.

SUITABLE FOR USE IN CLASS I, DIVISION 2, GROUPS A, B, C AND D HAZARDOUS LOCATIONS, OR NONHAZARDOUS LOCATIONS ONLY.

To comply with ATEX directives, the equipment must be installed within an IP54 enclosure and must be installed with a transient suppressor on the supply that does not exceed 140 % (33.6 V DC) of the nominal rated supply voltage.

Warnings

- **WARNING - EXPLOSION HAZARD - SUBSTITUTION OF ANY COMPONENTS MAY IMPAIR SUITABILITY FOR CLASS I, DIVISION 2.**
- **WARNING - EXPLOSION HAZARD - WHEN IN HAZARDOUS LOCATIONS, TURN OFF POWER BEFORE REPLACING OR WIRING MODULES.**
- **WARNING - EXPLOSION HAZARD - DO NOT DISCONNECT EQUIPMENT WHILE THE CIRCUIT IS LIVE OR UNLESS THE AREA IS KNOWN TO BE FREE OF IGNITABLE CONCENTRATIONS.**
- **WARNING - EXPLOSION HAZARD - THE USB CONNECTOR IS NOT FOR USE IN HAZARDOUS LOCATIONS AND FOR TEMPORARY CONNECTION ONLY. DO NOT USE, CONNECT OR DISCONNECT UNLESS THE AREA IS KNOWN TO BE NONHAZARDOUS. CONNECTION OR DISCONNECTION IN AN EXPLOSIVE ATMOSPHERE COULD RESULT IN AN EXPLOSION.**
- **WARNING - INSTALL IN AN ENCLOSURE CONSIDERED REPRESENTATIVE OF THE INTENDED USE.**

Attention!

- **ATTENTION – RISQUE D'EXPLOSION – LE REMPLACEMENT DE TOUT COMPOSANTS INVALIDE LA CERTIFICATION CLASS I, DIVISION 2.**
- **ATTENTION – RISQUE D'EXPLOSION – EN ZONE EXPLOSIVE, VEUILLEZ COUPER L'ALIMENTATION ÉLECTRIQUE AVANT LE REMPLACEMENT OU LE RACCORDEMENT DES MODULES.**
- **ATTENTION – RISQUE D'EXPLOSION – NE PAS DÉCONNECTER L'ÉQUIPEMENT TANT QUE L'ALIMENTATION EST TOUJOURS PRÉSENTE OU QUE LE PRODUIT EST TOUJOURS EN ZONE EXPLOSIVE ACTIVE.**
- **ATTENTION – RISQUE D'EXPLOSION – LE CONNECTEUR USB N'EST PAS FAIT POUR UN USAGE EN MILIEU EXPLOSIF. NE PAS, BRANCHER ET DEBRANCHER SANS SAVOIR SI LA ZONE N'EST PAS IDENTIFIÉE NON EXPLOSIVE. BRANCHER OU DEBRANCHER EN ZONE EXPLOSIVE PEUT ENTRAÎNER UNE EXPLOSION.**
- **AVERTISSEMENT – INSTALLER DANS UNE ARMOIRE VERROUILLEE VALIDANT L'ACTE VOLONTAIRE D'UTILISATION.**

UL Certification



LISTED 67AM

ATEX Certification

EX nA ic IIC T4 Gc



DEMKO 12 ATEX 1062548X

EMC Compliance (CE)



This product is in accordance with the EMC directive 2014/30/EU through conformance with the following standards:

- **EN 61000-6-4 (2007)**
Emission standard for industrial environment
EN 55016-2-3, Class A (2010)
EN 55022, Class A (2011)
- **EN 61000-6-2 (2005)**
Immunity for industrial environment
EN 61000-4-2 (2009)
EN 61000-4-3 (2006)
EN 61000-4-4 (2012)
EN 61000-4-5 (2014)
EN 61000-4-6 (2014)

HMS Industrial Networks AB
Box 4126
300 04 Halmstad, Sweden
info@hms.se



Further information and documents about this product can be found at the product pages on www.anybus.com.